

STATE OF SOUTH CAROLINA )  
 )  
COUNTY OF DORCHESTER )

ORDINANCE NUMBER 21-07

**AN ORDINANCE SUPPLEMENTING THE CODE OF ORDINANCES, DORCHESTER COUNTY, SOUTH CAROLINA, BY ADDING TO CHAPTER 38, A NEW ARTICLE VIII, REGULATING THE INSTALLATION OF SPEED HUMPS ON COUNTY MAINTAINED ROADS**

BE IT ORDAINED by the Dorchester County Council, duly assembled that the Code of Ordinances, Dorchester County, South Carolina is hereby supplemented by adding to Chapter 38, a new Article VIII, which shall read as follows:

**ARTICLE VIII. INSTALLATION OF SPEED HUMPS**

**SEC. 38-231. PURPOSE; DEFINITION; REQUESTS FOR INSTALLATION.**

1. The purpose of this ordinance is to provide guidance and objectivity in the evaluation and selection of roadways for the installation of speed humps. Where appropriate, other traffic-calming measures should be considered and/or implemented prior to the installation of speed humps. Prior to the approval and installation of speed humps, the Public Works Director (Director) shall authorize the type and location.
2. A "speed hump" shall be defined as a raised area intended to control vehicular speed in conformity with the details outlined herein, including the engineering specifications for maximum height, profile, and minimum and maximum length.
3. Request for speed humps shall be in writing and submitted to the Director by mail, email, or delivery to the Public Works Office. The general nature of the concern causing the request shall be stated. Such reasons may include, but are not limited to, excessive speeding or "cut through traffic." Speed hump request evaluations will be handled in the order in which they are received. Roads approved for installation of speed humps shall be placed on an approval list subject to private funding and approval by the Director of Public Works.

**SEC. 38-232. ELIGIBILITY REQUIREMENTS**

1. A request is only eligible for consideration if the following criteria are met:
  - a. The roadway must be a County maintained, local, residential, paved, public street with a minimum 20' travelway.
  - b. The road must be in reasonably good condition as determined by the Director.
  - c. The roadway must be a two-lane residential road with a posted speed limit of twenty-five miles per hour (25 mph) or less.
  - d. Have average speeds that exceed the posted speed limit.

- e. Have 85 percent of the residents living within the impacted area, as determined by the Public Works Director or designee, sign a petition requesting the traffic calming device and appointing a contact person for the request. The petition must identify the specific proposed location(s) of the traffic calming device(s). All residents within 200 feet of the proposed location(s) must sign in support of the request.

#### **SEC. 38-233. EVALUATION PROCESS**

1. All requests that meet the initial eligibility criteria will be formally evaluated as listed below:
  - a. After determination of the impacted area as defined by the Director, the applicant shall provide written notice to all residents within such area advising of the request and the right of any resident to object by providing written notice of objection to the attention of the Director within ten (10) days of the receipt of notice of the request. Notice to residents shall be by certified mail, return receipt requested. Applicants must submit proof of notice by providing the Director with receipts from each resident within the impacted or project area, or proof of mailing and failure of a resident to accept notice.
  - b. Public Works department will solicit feedback from the Sheriff's Office, Fire Department, and EMS Department.
  - c. If speed humps are determined acceptable by the Director, a recommendation shall be forwarded to the County Administrator for review, and to County Council for approval.

#### **SEC. 38-234. DESIGN AND CONSTRUCTION**

1. Speed hump layout and design will be determined by the Director. All construction shall conform to the details and specifications outlined herein or a suitable equivalent as determined by the Public Works Director.
2. Generally, speed humps should have a maximum profile of three inches (3") with a maximum twenty-two-foot-long (22') base. The distance between speed humps shall be at the discretion of the Director.
3. All signage and pavement markings shall conform to the current Manual of Uniform Traffic Control Devices for Streets and Highways (MUTCD). Adequate signing is a requirement for both permanent and temporary speed humps.
4. Speed Humps shall not be placed in a location that will interfere with the County's drainage system or utilities.
5. The applicant should be aware that permanent speed humps will be completely removed and will not be reusable if the County removes them for resurfacing operations. All cost associated with replacing the speed humps will be the responsibility of the applicant.

### **SEC. 38-235. TEMPORARY SPEED HUMPS**

1. Temporary speed humps may be utilized in place of asphalt speed humps if approved by the Director.
2. Temporary speed hump design and construction must be equivalent to detail included in this ordinance or an acceptable equivalent as determined by the Public Works Director.
3. Temporary speed humps may cost less and can be removed for road repairs and replaced afterwards by the applicant at its cost.
4. Temporary speed humps may be removed by the County for road repair and/ or resurfacing. The County will not be responsible for any damage to the speed hump during the removal process, and the County will not store the temporary speed hump during the course of the road repairs and/ or resurfacing. Repairs to, storage of, and replacement parts for the re-installation of temporary speed humps will be the responsibility of the applicant, Home Owners Association, project area residents or designated representative.

### **SEC. 38-236. SPEED HUMP REMOVAL**

1. The County reserves the right to remove the speed hump(s) at any time for any reason, to include maintenance and/or resurfacing of the road. Replacement and/or reconstruction of the speed hump including all cost associated shall be the responsibility of the applicant, Home Owners Association, project area residents, or designated representative.
2. As directed by the Director, once a Speed Hump is removed, replacement may require a new application, as well as, completion of Section 2 and 3.

### **SEC. 38-237. PAYMENT**

1. The applicant, Home Owners Association, project area residents, or designated representative is responsible for the total cost of the speed hump and signage installation cost, and all associated maintenance cost for the signs and speed hump.
2. If a speed hump is removed for road resurfacing or repairs, the County will remove the speed hump at the cost of the County; however, the speed hump replacement and repair cost will be the responsibility of the applicant, Home Owners Association, project area residents, or designated representative.

### **SEC. 38-238. CONSTRUCTION DETAILS**

1. Flat-Topped Speed Hump (See attached)
2. Parabolic Speed Hump (See attached)

This Ordinance shall be effective upon third and final reading.

Except as specifically Supplemented herein, the Dorchester County Code of Ordinances shall remain in full force and effect.

Approved and adopted on this 3rd day of May, 2021.

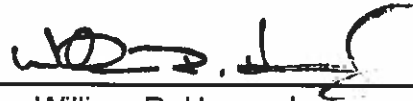

William R. Hearn, Jr.  
Chairman Dorchester  
County Council

First Reading: 03/01/2021  
Second Reading: 04/19/2021  
Public Hearing: 04/19/2021  
Third Reading: 05/03/2021

ATTEST:

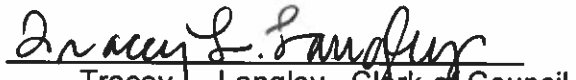
  
Tracey L. Langley, Clerk of Council

# Construction Detail

Not to Scale

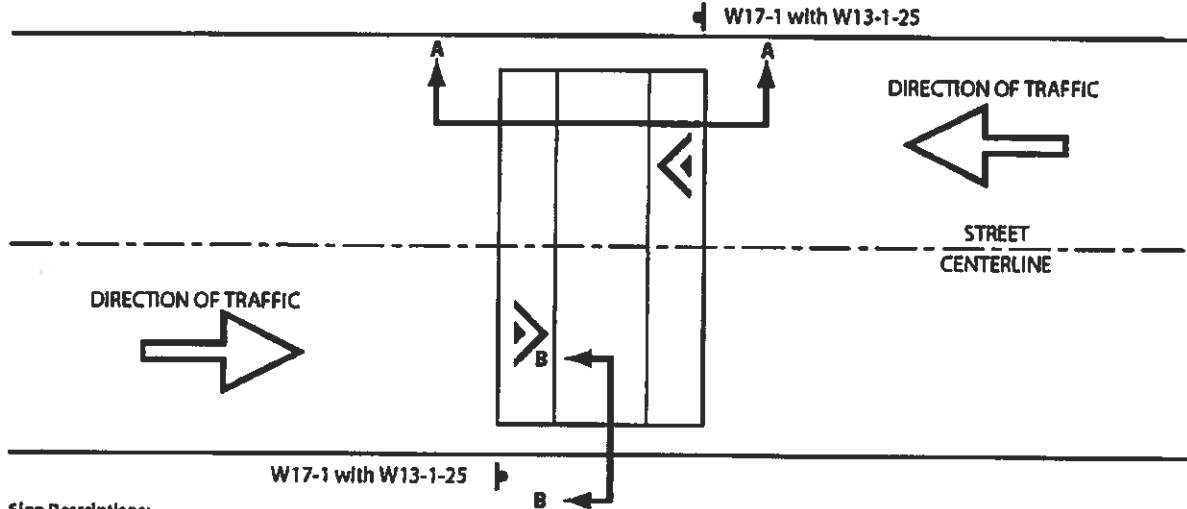

Sign Descriptions:  
 W17-1 (Speed Hump Sign)  
 W13-1 (Advisory Speed Plaque)

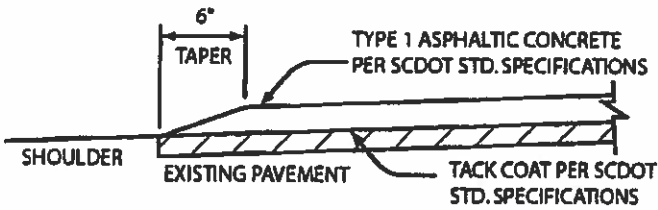
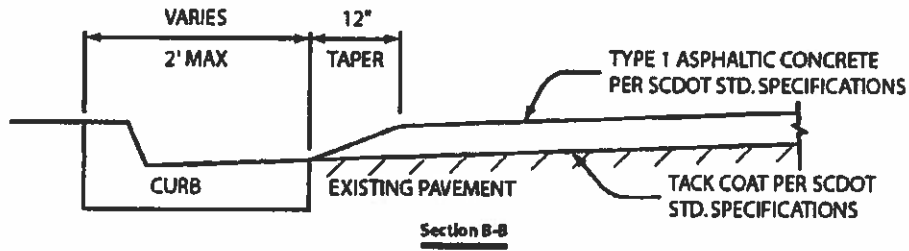
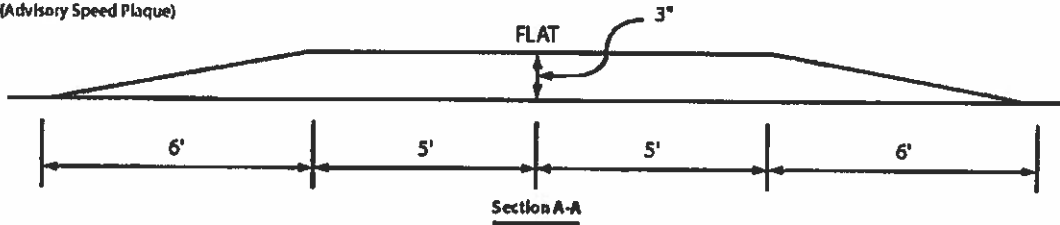

Shoulder Detail for Street Without Curbs

**Note:**  
 All materials must be approved by the Public Works Director. Actual dimensions may be changed at the discretion of the Public Works Director.

## FLAT-TOPPED SPEED HUMP

# Construction Detail

Not to Scale

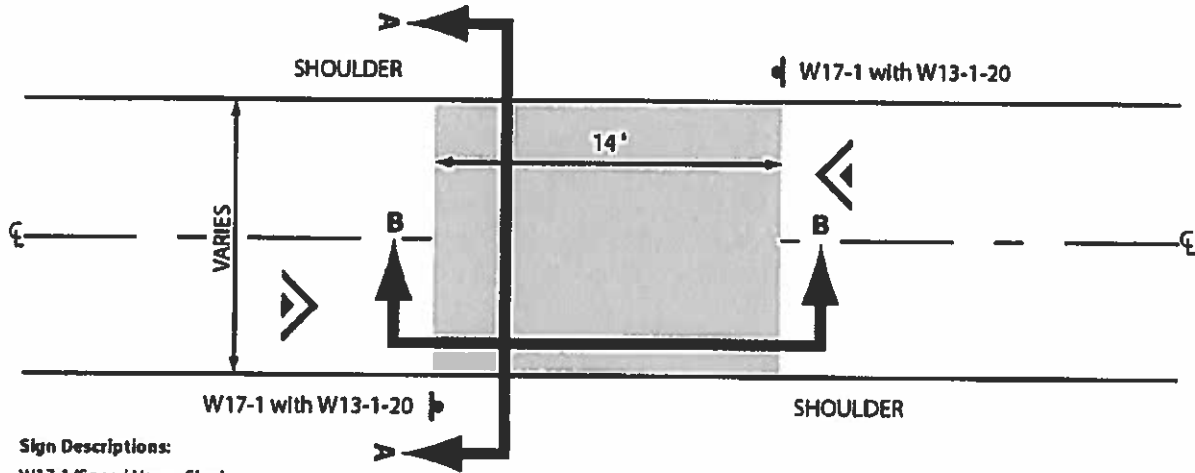

Sign Descriptions:  
W17-1 (Speed Hump Sign)  
W13-1 (Advisory Speed Plaque)

\*Use 12" taper with curb & gutter, not encroaching into gutter area.



Section A-A

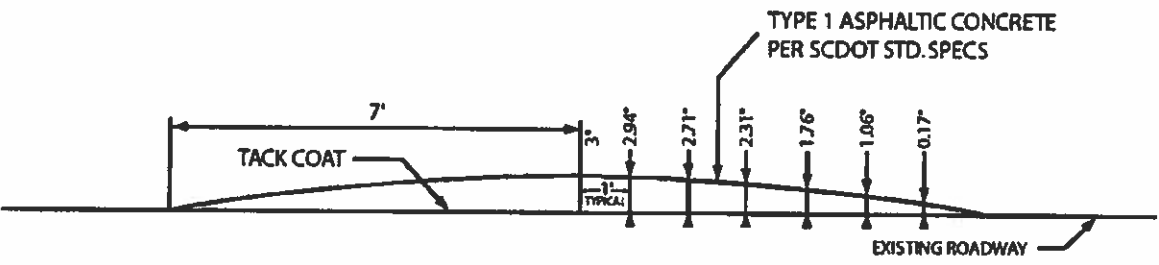

PARABOLIC CROWN

Section B-B

**Note:**  
All materials must be approved by the Public Works Director.  
Actual dimensions may be changed at the discretion of the Public Works Director.

## PARABOLIC SPEED HUMP