

CAST IRON COVER

TRACER WIRE SHALL NOT BE INSTALLED INSIDE THE SPOOL PIECE. IT SHALL ENTER AND EXIT THE VALVE BOX WHERE THE TOP SECTION OF THE BOX SCREWS TOGETHER WITH THE BOTTOM SECTION.

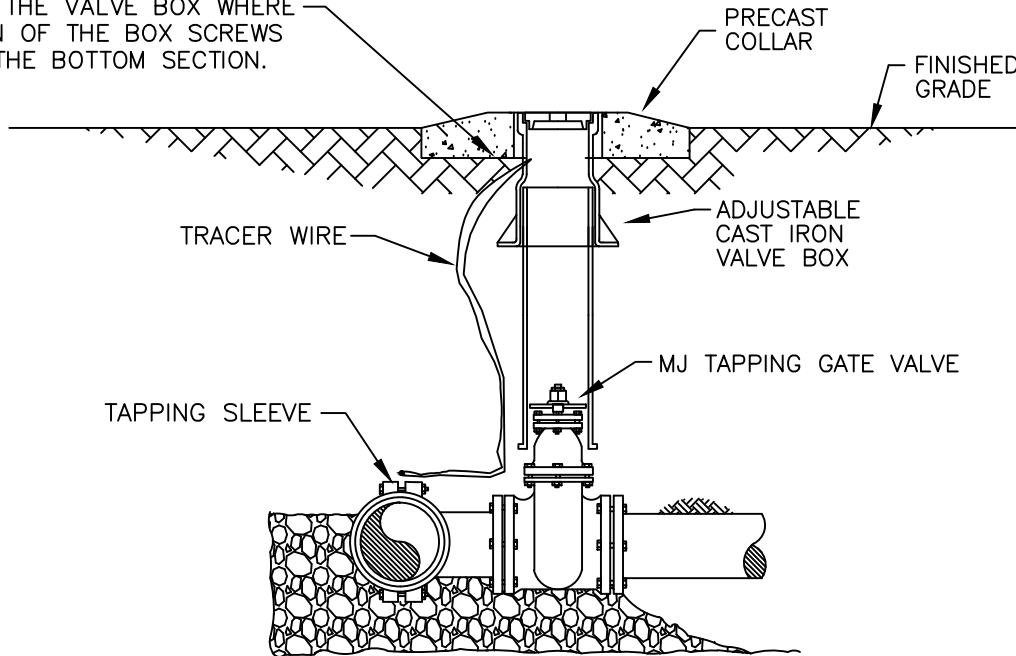

SUPPORT VALVE ASSEMBLY WITH #57 STONE. (STONE TO EXTEND MINIMUM OF 6" UNDER INVERT)

NOTES:

1. VALVES TO OPEN COUNTER CLOCKWISE.
2. ALL TAPPING SLEEVES GREATER THAN 2" SHALL BE HYDROSTATICALLY PRESSURE TESTED TO 150 PSI FOR 20 MINUTES.
3. TAP DIAMETER SHALL BE WITHIN $\frac{1}{8}$ " OF LINE DIAMETER.

PIPE O.D.

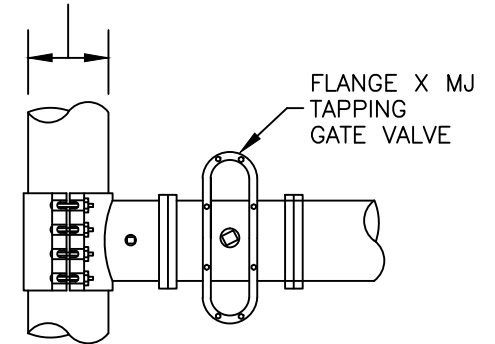

DORCHESTER COUNTY WATER & SEWER	
TAPPING SLEEVE AND VALVE	DRAWING: W-15
DATE: <u> JUNE 2018 </u>	DRAWN BY: <u> STL </u>
SCALE: <u> NTS </u>	APPROVED BY: <u> JDC </u>